



RED SWASTIKA SCHOOL

RED SWASTIKA SCHOOL

2011 PRELIMINARY EXAMINATION

MATHEMATICS PAPER 1

Name : _____ ()

Class : Primary 6 / _____

Date : 25 Aug 2011

BOOKLET A

15 Questions

20 Marks

Duration of Paper 1 (Booklets A & B): 50 minutes

Note:

1. Do not open this Booklet until you are told to do so.
2. Read carefully the instructions given at the beginning of each part of the Booklet.
3. Do not waste time. If a question is difficult for you, go on to the next one.
4. Check your answers thoroughly and make sure you attempt every question.
5. In this booklet, you should have the following:
 - (a) Page 1 to Page 5
 - (b) Questions 1 to 15
6. You are not allowed to use a calculator.

Questions 1 to 10 carry 1 mark each. Questions 11 to 15 carry 2 marks each. For each question, four options are given. One of them is the correct answer. Make your choice (1, 2, 3 or 4). Shade the correct oval (1, 2, 3 or 4) on the Optical Answer Sheet. (20 marks)

1 In 48.96, what does the digit 6 stand for?

- (1) 6 thousandths
- (2) 6 hundredths
- (3) 6 tenths
- (4) 6 ones

2 What is the missing number in the box?

$$\begin{array}{r} 18 \\ \times 16 \\ \hline \end{array}$$

- (1) 12
- (2) 9
- (3) 6
- (4) 4

3 A carton of eggs costs \$2.40 after a 20% discount. What is the cost of the carton of eggs before discount?

- (1) \$12
- (2) \$9.60
- (3) \$3
- (4) \$1.20

4 In a class of 40 pupils, 28 of them wear glasses. What is the ratio of the number of pupils who do not wear glasses to the total number of pupils?

- (1) 3 : 7
- (2) 3 : 10
- (3) 7 : 3
- (4) 7 : 10

5. Express 125 minutes in hours and minutes:

- (1) 1 h 5 min
- (2) 1 h 25 min
- (3) 2 h 5 min
- (4) 2 h 25 min

6. What is the area of Triangle EFG shown below?

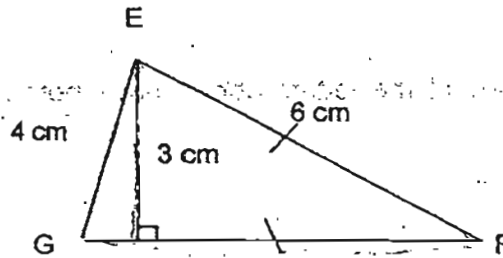

- (1) 9 cm^2
- (2) 12 cm^2
- (3) 13 cm^2
- (4) 16 cm^2

7. What is the capacity of a cubical tank of side 8 cm?

- (1) 0.64 l
- (2) 0.512 l
- (3) 5.12 l
- (4) 64 l

- 8 In the diagram below, the letters M, A, T, H are drawn on a square grid.

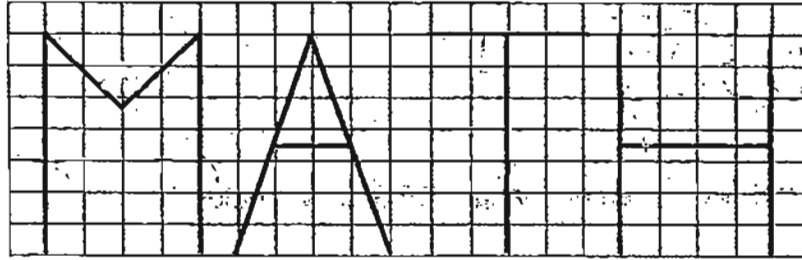

How many of the letters above have both parallel and perpendicular lines?

- (1) 1
 (2) 2
 (3) 3
 (4) 4
- 9 The mass of Mr Bala is 70 kg when rounded off to the nearest kilogram. Which one of the following is possibly the mass of Mr Bala?

- (1) 68.9 kg
 (2) 69.1 kg
 (3) 70.1 kg
 (4) 70.9 kg

- 10 The net below is folded to form a cube. What is the missing symbol on the top face of the cube?

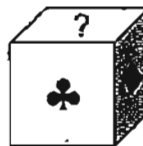
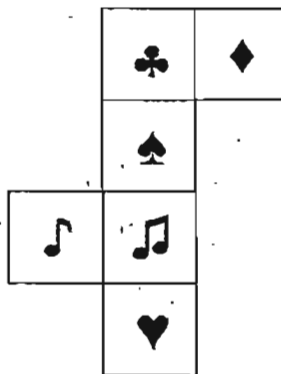

- (1) ♪
 (2) ♠
 (3) ♪
 (4) ♥

- 11 WXY is an equilateral triangle and $WY = YZ$. Find $\angle WZY$.

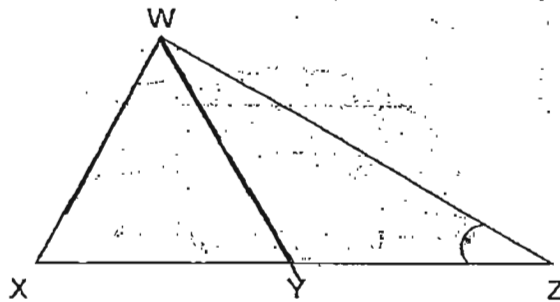

- (1) 15°
- (2) 30°
- (3) 60°
- (4) 120°

- 12 A bus left the terminal at 9.30 am. It arrived at its destination which was 840 km away at 4.30 pm. What was its average speed?

- (1) 120 km/h
- (2) 168 km/h
- (3) 4 200 km/h
- (4) 5 880 km/h

- 13 The figure below shows three right-angled Triangles A, B and C overlapping one another. The area of Triangle A is $\frac{1}{2}$ the area of Triangle B and the area of Triangle B is $\frac{1}{2}$ the area of Triangle C. What is the ratio of the shaded area to the area of the whole figure?

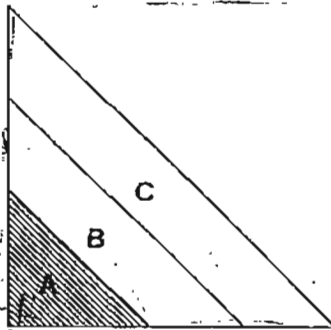

- (1) 1 : 2
- (2) 1 : 3
- (3) 1 : 4
- (4) 1 : 5

- 14 The width of the shaded figure is 3.5 cm. Find the perimeter of the shaded figure. (Take $\pi = \frac{22}{7}$)

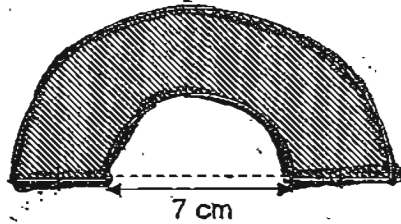

- (1) 33 cm
(2) 40 cm
(3) 66 cm
(4) 73 cm
- 15 The figure below shows a poster at the school bookshop.

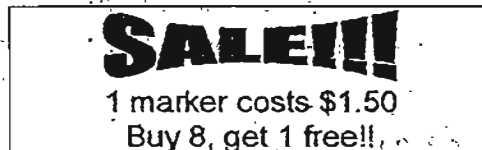

How many markers would Shawn get if he had paid \$18 altogether?

- (1) 11
(2) 12
(3) 13
(4) 14



RED SWASTIKA SCHOOL

RED SWASTIKA SCHOOL

2011 PRELIMINARY EXAMINATION

MATHEMATICS PAPER 1

Name : _____ ()

Class : Primary 6 / _____

Date : 25 Aug 2011

BOOKLET B

15 Questions
20 Marks

In this booklet, you should have the following:

- (a) Page 6 to Page 13
- (b) Questions 16 to 30

MARKS

	OBTAINED	POSSIBLE
BOOKLET A		20
BOOKLET B		20
TOTAL		40

Parent's Signature : _____

Questions 16 to 25 carry 1 mark each. Write your answers in the spaces provided. For questions which require units, give your answers in the units stated. (10 marks)

16 Find the sum of $\frac{1}{4}$ and $\frac{4}{100}$ as a decimal.

Ans: _____

17 Find the perimeter of the quadrant shown below. (Take $\pi = \frac{22}{7}$)

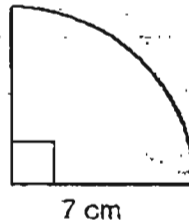

Ans: _____ cm

18 Sam took 2 minutes to cut a wooden plank into 2 pieces. How long would he take to cut the same plank into 10 pieces?

Ans: _____ min

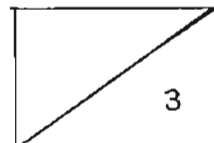

19 Shade one more square to make the figure symmetrical.

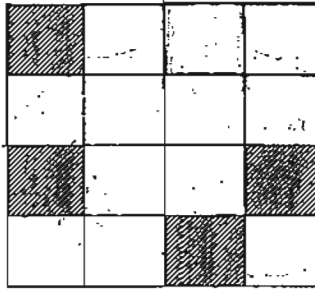

20 What is the missing number in the blank if the average of the numbers is 12?

0, 14, 22, _____, 6

Ans: _____

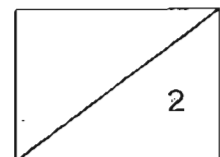

The pie chart below shows the result of a survey on the favourite brands of mobile phones of a class of 40 pupils. Use the information to answer Questions 21 and 22.

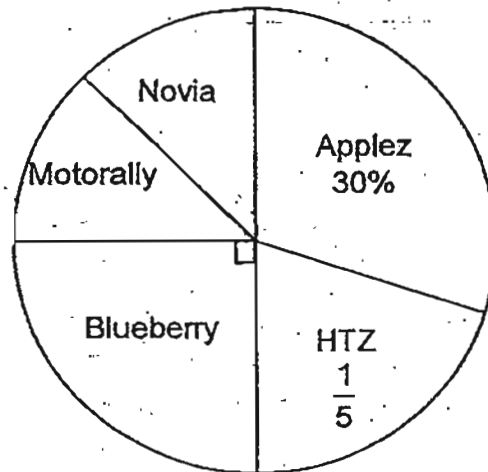

- 21 Using the data in the pie chart, draw the bars to represent the number of pupils whose favourite brands are Motorally and Novia if there is an equal number of pupils who like these two brands best.

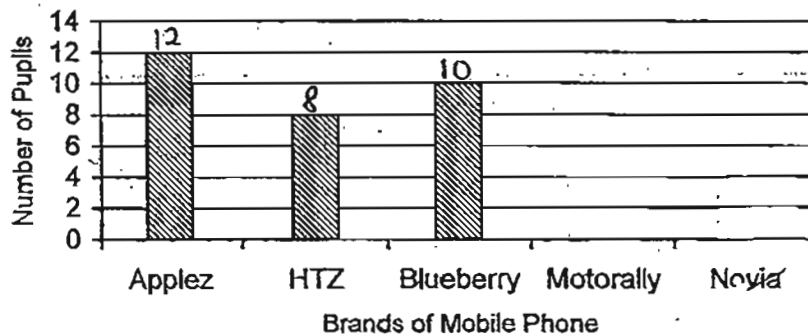

- 22 If 2 pupils whose favourite brand was Applez were transferred to the class, what is the percentage of pupils whose favourite brand is Applez now?

Ans: _____ %

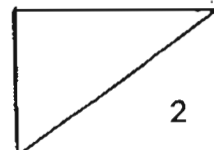

- 23 The figure below is made up of a rectangle; an equilateral triangle and an isosceles triangle. Find $\angle w$.

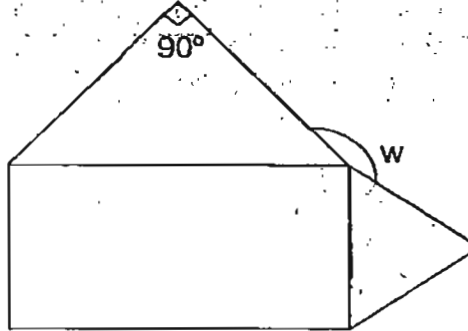

Ans: _____^o

- 24 Keegan left Town X for Town Y, travelling at an average speed of 60km/h. 45 minutes later, Hamid left Town X for Town Y travelling at the same speed as Keegan. How far ahead was Keegan when Hamid left Town X?

Ans: _____ km

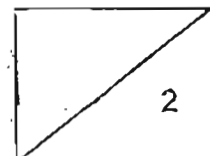

- 25 Mr and Mrs Leong left their house at the same time but travel in opposite directions. Mr Leong travelled towards Bedok while Mrs Leong headed for Kallang. Mrs Leong drove at a speed which was 10 km/h slower than Mr Leong. 30 minutes later, when Mr Leong reached Bedok, they were 95 km apart. How far did Mrs Leong travel when Mr Leong reached Bedok?

Ans: _____ km

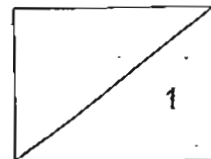

Questions 26 to 30 carry 2 marks each. Show your working clearly in the space provided for each question and write your answers in the spaces provided. For questions which require units, give your answers in the units stated. (10 marks)

26 $\frac{4}{5}$ of a number is 450. What is the number?

Ans: _____

27 ABCD is a square. What is the ratio of the area of the shaded parts to the area of the unshaded parts?

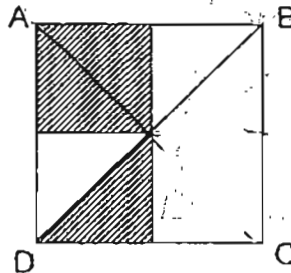

Ans: _____

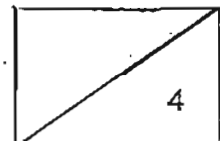

- 28 The figure below shows two identical parallelograms and a rhombus. Find $\angle q$.

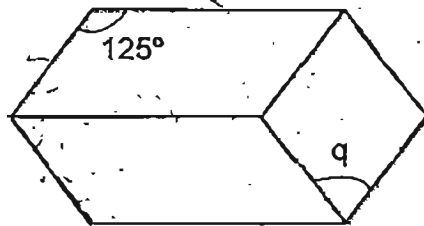

Ans: _____

- 29 ABC and ADE are triangles where $AE = ED$. Find $\angle ABC$.

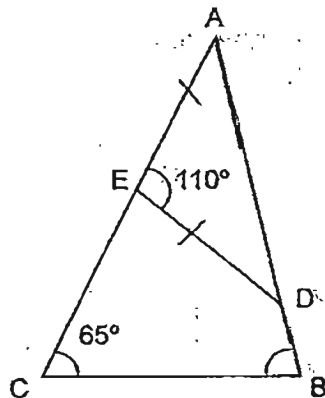

Ans: -- _____

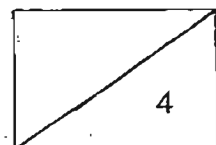

- 30 A hawker sold 10 plates of chicken rice at \$3 each and made an overall profit of \$x. Find the cost of each plate of chicken rice.

Ans: \$ _____

END OF PAPER 1

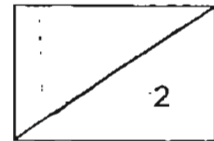



RED SWASTIKA SCHOOL

RED SWASTIKA SCHOOL

2011 PRELIMINARY EXAMINATION

MATHEMATICS PAPER 2

Name : _____ ()

Class : Primary 6 / _____

Date : 25 Aug 2011

18 Questions,

60 Marks

Duration of Paper 2: 1 hour 40 minutes

Note:

1. Do not open this Booklet until you are told to do so.
2. Read carefully the instructions given at the beginning of each part of the Booklet.
3. Do not waste time. If a question is difficult for you, go on to the next one.
4. Check your answers thoroughly and make sure you attempt every question.
5. In this paper, you should have the following:
 - (a) Page 1 to Page 13
 - (b) Questions 1 to 18
6. You are allowed to use a calculator.

MARKS

	OBTAINED	POSSIBLE
PAPER 1		40
PAPER 2		60
TOTAL		100

Parent's Signature : _____

Questions 1 to 5 carry 2 marks each. Show your working clearly in the space below each question and write your answers in the spaces provided. For questions which require units, give your answers in the units stated.

(10 marks)

-
- 1 A 2-digit number when divided by 9 gives a remainder of 5. What is the largest possible number?

Ans: _____

-
- 2 A carton can either hold 180 cuboids or 220 cubes. When 108 cuboids are already in the carton, what is the maximum number of cubes that can be put in the carton?

Ans: _____

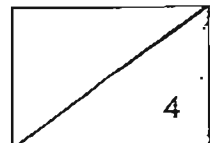

3. The diagram below is made up of two circles and a rectangle. The perimeter of the rectangle is 34 cm. If XY is the radius of the bigger circle, find the area of the shaded part. (Take $\pi = \frac{22}{7}$)

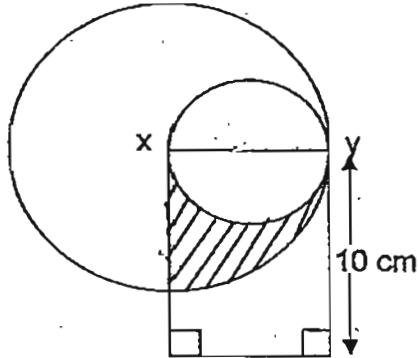

Ans: _____ cm²

4. The figure below is made up of a rhombus ABCD and PQ // RS. Find $\angle QBC$.

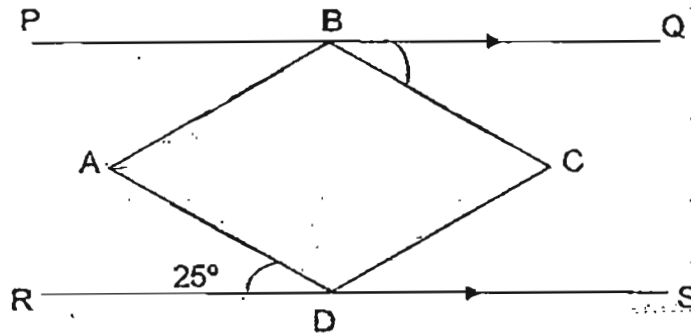

Ans: _____ °

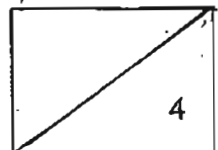

5 Look at the number patterns in the squares. What is the missing number in the square?

$2x$	$6x$
x	$3x$

$4a$	$12a$
$2a$	$6a$

$6h$	$18h$
$3h$	

Ans: _____

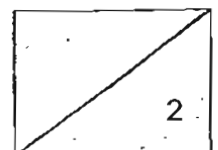

For Questions 6 to 18, show your working clearly in the space below each question and write your answers in the spaces provided.
The number of marks available is shown in brackets [] at the end of each question or part-question. (50 marks)

- 6 Shawn saved $\frac{2}{5}$ of his pocket money every month. When Shawn's pocket money was reduced by $\frac{1}{10}$, his savings become \$18. What was his pocket money at first?

Ans: _____ [3]

- 7 $\frac{1}{4}$ of a 400-gram pancake mixture is sugar. Another 100 g of sugar is added to the mixture. What fraction of the final mixture is sugar? (Leave your answer in its simplest form.)

Ans: _____ [3]

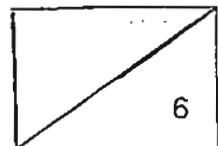

- 8 The ratio of the number of apples in Box A to the number of apples in Box B is 3 : 2. All the apples in Box B are green. The ratio of the number of green to the number of red apples in Box A is 4 : 5. There are 20 more green apples in Box B than in Box A. How many red apples are there?

Ans: _____ [3]

- 9 The perimeter of a rectangular piece of paper is 96 cm. The paper is folded to form 2 identical squares and an isosceles triangle as shown below. Find the ratio of the perimeter of the paper to the length of the rectangular piece of paper. (Leave your answer in its simplest form.)

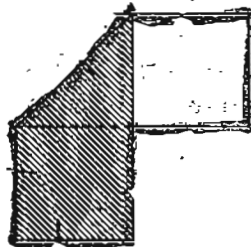

Ans: _____ [3]

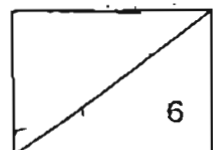

10 Katelyn had some green, red and blue ribbons. She had 25% more green ribbons than red ribbons and 20% less blue ribbons red ones.

- (a) What is the ratio of red ribbons to green ribbons to blue ribbons?
- (b) Katelyn exchanges all her blue ribbons for some red and green ribbons. She now has an equal number of red and green ribbons. How many more green than red ribbons did she have at first if she has 244 red ribbons now?

Ans: (a) _____ [2]

(b) _____ [3]

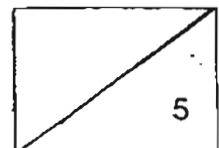

- 11 The figure below is made up of a square ABCD and a circle. O is the centre of the circle and the square. Given that the area of the square is 784 cm^2 , find the area of the shaded parts. (Take $\pi = 3.14$)

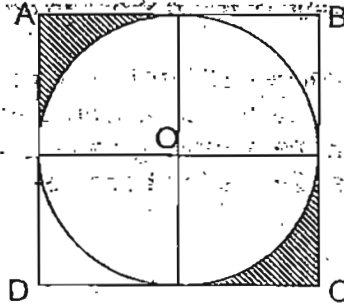

Ans: _____ [3]

- 12 The average of 6 numbers on a piece of paper is 50. A digit from each of the last two numbers are missing. What is the sum of the value of the two missing digits?

48	36	42	58	5		6
----	----	----	----	---	---	---

Ans: _____ [4]

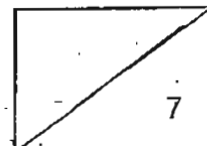

13. Complete the figure by drawing isosceles triangle EFG where $\angle EFG = 80^\circ$. $EF = FG$. The line EF has been drawn for you.

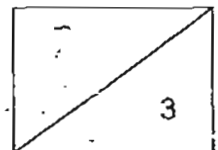
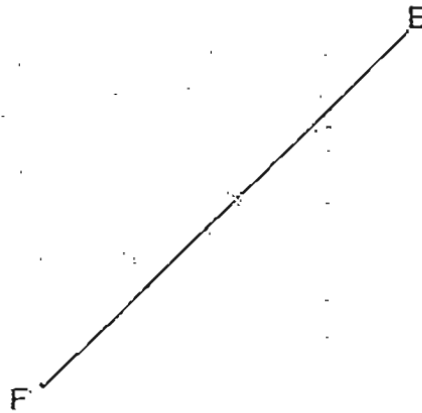

14. Tank A, measuring 60 cm by 36 cm by 50 cm is filled with water to the brim. Half of the water in Tank A is poured into a cubical tank, Tank B. The water fills $\frac{1}{4}$ of Tank B. What is the height of Tank B?
(Give your answer in m.)

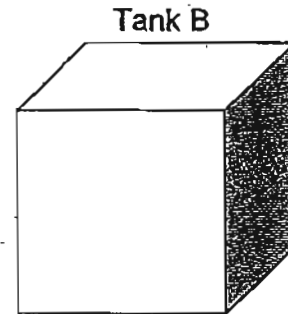
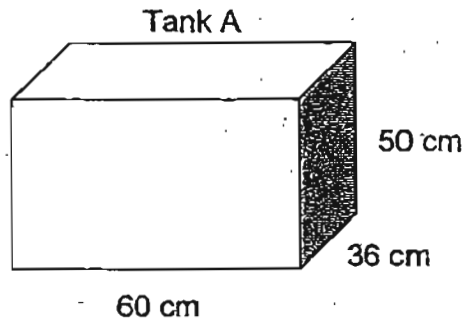

Ans: _____ [4]

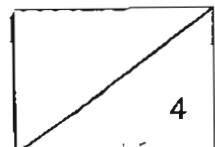

- 15 Eugene, Freddy and George had some playing cards. Freddy had 200 more playing cards than Eugene. George had $\frac{3}{4}$ the number of cards Freddy had. After George lost $\frac{1}{6}$ of his cards to Eugene, he had 320 fewer cards than Eugene. What was the ratio of the number of cards Eugene had to the number of cards Freddy had to the number of cards George had in the end?

Ans: _____ [4]

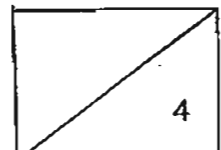

16. Laura and Ahmad have some stamps. If Laura gives 80 stamps to Ahmad, he will have five times the number of stamps as she has. If Ahmad gives 120 stamps to Laura, she will have $\frac{1}{3}$ as many stamps as Ahmad. How many stamps does Laura have at first?

Ans: _____ [5]

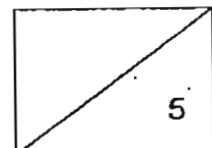

17 A shopkeeper had some blue and red pens in his book shop. There were twice as many red pens as blue pens. The shopkeeper sold the pens in bundles of 2 red pens and 3 blue pens. After selling all the blue pens, he still had 120 red pens left. How many pens did he have in his bookshop at first?

Ans: _____ [5]

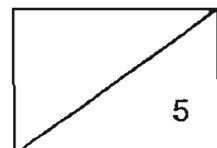

- 18 The figure below shows a rectangle and 2 quadrants. The radii of the 2 quadrants are 8 cm and 16 cm respectively. Find the difference in area between the two shaded parts X and Y. (Take $\pi = 3.14$)

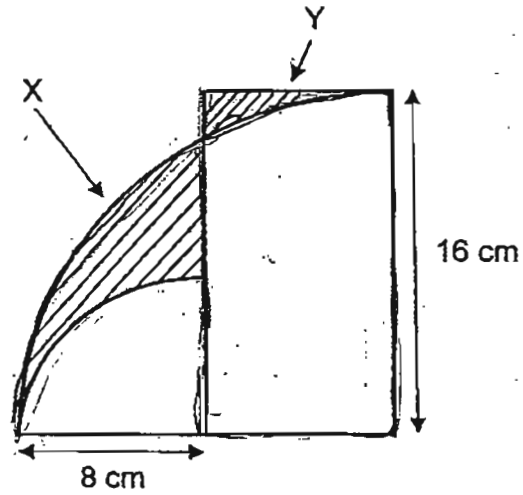

Ans: _____ [5]

END OF PAPER 2

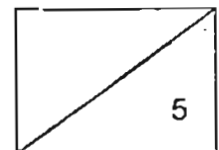

Answer Ke

EXAM PAPER 2011

SCHOOL : RED SWASTIKA
SUBJECT : PRIMARY 6 MATHEMATICS

TERM : PRELIMINARY

Q1	Q2	Q3	Q4	Q5	Q6	Q7	Q8	Q9	Q10	Q11	Q12	Q13	Q14	Q15
2	1	3	2	3	1	2	2	3	4	2	1	3	2	3

16) 0.29

17) 25cm

18) 18min

19)

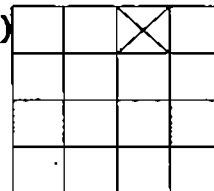

20) 18

21)

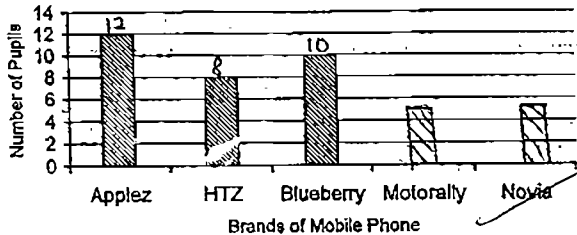

22) $33\frac{1}{3}\%$

23) 165°

24) 45km

25) 45km

26) 562.5

27) 3:5

28) 70°

29) 80°

30) $\$(30 - x / 10)$

Paper 2

1) Largest no. divided by 9 $\rightarrow 99$

2nd largest no. divided by 9 $\rightarrow 90$

Largest possible no $\rightarrow 90 + 5 = 95$

2) $108 \div 9 = 12$

$12 \times 11 = 132$

$220 - 132 = 88$

3) Breadth of rectangle $\rightarrow (34\text{cm} - 10\text{cm} - 10\text{cm}) \div 2 = 7\text{cm}$

Area of quadrant $\rightarrow \frac{1}{4} \times \frac{22}{7} \times 7\text{cm} \times 7\text{cm} = 38.5\text{cm}^2$

Area of semicircle $\rightarrow \frac{1}{2} \times \frac{22}{7} (7\text{cm} \div 2) \times (7\text{cm} \div 2) = 19.25\text{cm}^2$

Area of shaded $\rightarrow 38.5\text{cm}^2 - 19.25\text{cm}^2 = 19.25\text{cm}^2$

4) $\angle ADC \rightarrow 180^\circ - 25^\circ - 25^\circ = 130^\circ$

$\angle ABC \rightarrow 130^\circ$

$\angle QBC \rightarrow (180^\circ - 130^\circ) \div 2 = 25^\circ$

5) $18h \times 3 = 54h$

$54h \div 6 = 9h$

The missing no. of the square is 9h

6) $1 - \frac{1}{10} = \frac{9}{10}$

$\frac{2}{5} \times \frac{9}{10} = \frac{9}{25}$

9 units $\rightarrow \$18$

1 unit $\rightarrow \$18 \div 9 = \2

25 units $\rightarrow \$2 \times 25 = \50

Shawn's pocket money at first \$50

7) Original amt of sugar $\rightarrow \frac{1}{4} \times 400\text{g} = 100\text{g}$

New amt. of sugar $\rightarrow 100\text{g} + 100\text{g} = 200\text{g}$

New amt. of mixture $\rightarrow 400\text{g} + 100\text{g} = 500\text{g}$

Fraction $\rightarrow \frac{200}{500} = \frac{2}{5}$

8) 2units \rightarrow 20

1unit \rightarrow $20 \div 2 = 10$

5units \rightarrow $10 \times 5 = 50$

There are 50 red apples.

9) Length : Breadth

3 : 1

8units \rightarrow 96cm

1unit \rightarrow $96\text{cm} \div 8 = 12\text{cm}$

Length of the paper \rightarrow $12\text{cm} \times 3 = 36\text{cm}$

Perimeter : Length

96 : 36

8 : 3

10)a) Red : 100%

Green: 125%

Blue: 80%

R : G : B

$\times 5$ 100: 125: 80

20 : 25 : 16

Ratio \rightarrow 20:25:16

b) 61units \rightarrow 244

1unit \rightarrow $244 \div 61 = 4$

10units \rightarrow $4 \times 10 = 40$

11) Length of AB $\rightarrow \sqrt{784\text{cm}^2} = 28\text{cm}$

Length of AE \rightarrow $28 \div 2 = 14\text{cm}$

Area of small square \rightarrow $14\text{cm} \times 14\text{cm} = 196\text{cm}^2$

Area of quadrant \rightarrow $\frac{1}{4} \times 3.14 \times 14\text{cm} \times 14\text{cm}$
 $= 153.86\text{cm}^2$

Area of 1 shaded part \rightarrow $196\text{cm}^2 - 153.86\text{cm}^2$
 $= 42.14\text{cm}^2$

Area of shaded parts \rightarrow $42.14\text{cm}^2 \times 2 = 84.28\text{cm}^2$

12) Total of the 6 numbers

\rightarrow $6 \times 50 = 300$

Total of the last 2 numbers

\rightarrow $300 - 48 - 36 - 42 - 58 = 116$

Sum of value \rightarrow $60 + 0 = 60$

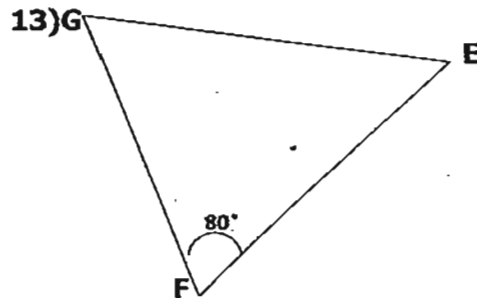

15) 97 : 104 : 65

14) Amt. of water poured into y=tank B

\rightarrow $\frac{1}{2} \times 60\text{cm} \times 36\text{cm} \times 50\text{cm} = 54000\text{cm}^3$

$\frac{1}{4}$ of capacity of Tank B \rightarrow 54000cm^3

Capacity of Tank B \rightarrow $54000\text{cm}^3 \times 4 = 216000\text{cm}^3$

Height of Tank B \rightarrow $\sqrt[3]{216000\text{cm}^3} = 60\text{cm} = 0.6\text{m}$

16) $4 \times (1\text{unit} + 80 + 120) = 6\text{units}$

$4 \times (1\text{unit} + 200) = 6\text{units}$

$4\text{units} + 800 = 6\text{units}$

$6\text{units} - 4\text{units} \rightarrow 800$

$2\text{units} \rightarrow 800 \div 2 = 400$

No. of stamps Laura has at first

\rightarrow $400 + 80 = 480$ stamps

17) $6\text{units} - 2\text{units} = 4\text{units}$

$4\text{units} \rightarrow 120 \div 4 = 30$

$8\text{units} \rightarrow 30 \times 9 = 270$

No. of pens he had in bookshop at first

\rightarrow 270 pens

18) Area of big quadrant \rightarrow $\frac{1}{4} \times 3.14 \times 16\text{cm} \times 16\text{cm} = 200.96\text{cm}^2$

Area of small quadrant \rightarrow $\frac{1}{4} \times 3.14 \times 8\text{cm} \times 8\text{cm} = 50.24\text{cm}^2$

Area of rectangle \rightarrow $8\text{cm} \times 16\text{cm} = 128\text{cm}^2$

Area of A \rightarrow $200.96\text{cm}^2 - 50.24\text{cm}^2 = 150.72\text{cm}^2$

Difference in area between the two shaded parts X and Y \rightarrow $150.72\text{cm}^2 - 128\text{cm}^2$
 $= 22.72\text{cm}^2$